

Use & Care guide

ELECTRIC RANGE

**ELECTRONIC
OVEN CONTROL
SELF-CLEANING**

SAFETY INSTRUCTIONS	4
ELECTRONIC OVEN CONTROL	6
SETTING THE CLOCK	7
USING THE MINUTE TIMER	8
USING THE SURFACE ELEMENTS	19
COIL ELEMENT COOKTOP MODELS	20
GLASS CERAMIC COOKTOP MODELS	20
COOKING TIPS	23
OVEN SELF-CLEANING CYCLE	27
CARING FOR YOUR RANGE	31
COIL ELEMENT REMOVAL/REPLACEMENT	31
IF YOU NEED ASSISTANCE OR SERVICE	41
WARRANTY	44

A NOTE TO YOU

You have purchased a quality, world-class electric range. Years of engineering experience have gone into its manufacturing. To ensure that you will enjoy many years of trouble-free operation, we have developed this User Guide. It is full of valuable information on how to operate and maintain your range properly and safely. Please read it carefully.

Also, please complete and mail the Ownership Registration Card provided with your range.

Your safety is important to us.

This guide contains safety symbols and statements. Please pay special attention to these symbols and follow any instructions given. Here is a brief explanation of the use of each symbol .

WARNING

This symbol will help you to avoid such dangers as personal injury, burns, fire and electrical shock.

CAUTION

This symbol will help you avoid actions which could cause product damage (scratches, dents, etc.) and damage to your personal property.

Should you ever require service for your range, you will need to know your appliance's complete model number and serial number. You can find this information on the model and serial number plate located behind the storage drawer panel, in view when the storage drawer is open. Also, please record the date the product was purchased/installed and the Builder or Store's name, address and phone number.

Keep this book and the sales slip together in a safe place for future reference.

NOTE: You must provide proof of purchase or installation date for in-warranty service.

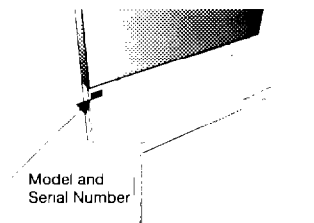

Model Number Store Name

Serial Number..... Address

Date Purchased..... Phone

Date Installed

TABLE OF CONTENTS

A NOTE TO YOU	2	COOKING TIPS	23
IMPORTANT SAFETY INSTRUCTIONS	4	Broiling	23
ELECTRONIC OVEN CONTROL	6	Air circulation	24
Display/clock	6	Oven rack positions	24
Using the control lock	6	For proper cooking, follow these guidelines	25
Setting the clock	7	Rack Placement for specific foods	25
Using the minute timer	8	Using aluminum foil in the oven	26
Starting/ Cancelling a function	9	OVEN SELF-CLEANING CYCLE	27
Baking & Roasting	10	How the self-cleaning cycle works	27
Adjusting oven temperature control	12	Before you start	27
Broiling	14	For best cleaning results	28
Vari-Broil	16	Automatic door lock	28
ADDITIONAL RANGE FEATURES	17	Setting the controls	29
Oven vent	17	To stop the self-cleaning cycle at any time	30
Coil element cooktop models	17	CARING FOR YOUR RANGE	31
Glass ceramic cooktop models	17	Coil element cooktop models	31
Broiler pan storage rack	17	Coil element removal/replacement	31
Automatic oven light	18	Lift up cooktop	32
Fluorescent cooktop light	18	Glass ceramic cooktop models	33
Appliance outlet	18	Cleaning tips	34
USING THE SURFACE ELEMENTS	19	Convenient cleaning features	35
Surface element controls	19	Removable oven door	35
Power on lights	19	Sweep-through base	36
Control setting guide	19	Removable control console glass	36
Coil element cooktop models	20	Cleaning chart	37
Simmer element	20	Replacing light bulbs & resetting breakers	39
Glass ceramic cooktop models	20	Cooktop light replacement	39
Glass ceramic cooktop elements	20	Oven light replacement	39
Hot surface indicator lights	21	Appliance outlet circuit breaker	40
COOKWARE	22	IF YOU NEED ASSISTANCE OR SERVICE	41
Home canning information	22	Troubleshooting	41
		WARRANTY	44

WARNING

To reduce the risk of fire, electrical shock, injury to persons, or damage when using the range, follow basic precautions, including the following:

General

- Read all instructions before using the range.
- Install or locate the range only in accordance with the provided Anti-Tip Bracket and Installation Instructions.
- **CAUTION:** Do not store things children might want above the range. Children could be burned or injured while climbing on it.



- Do not stand on the oven door or drawer.
- Do not leave children alone or unattended in area where the range is in use. They should never be allowed to sit or stand on any part of the range. They could be burned or injured.
- Do not operate the range if it is damaged or not working properly.
- Do not use the range for warming or heating the room. Persons could be burned or injured, or a fire could start.
- Use the range only for its intended use as described in this manual.
- Be sure all parts of the range are cool,



especially heating elements, before touching with bare hands, cleaning cloth or cleaning materials.

Coil element cooktop models:
Allow the cooktop to cool
before lifting to clean.

- A glowing light on the control panel indicates a switch is turned on. Be sure it indicates the element you want to use. Let it serve as a reminder to turn off the element when cooking is completed.
- Be careful to keep appliance cords away from surface elements to prevent possible damage to cord.

IMPORTANT SAFETY INSTRUCTIONS

- Do not store plastic or flammables in the oven drawer or oven cavity.
- Do not store flammable materials on or near the range. The fumes can create an explosion and/or fire hazard.
- In the event of a fire caused by burning food inside the oven:
 - Keep the oven door closed.
 - Turn the oven control off.
 - Turn off the power source.
 - Call the Fire Department if the fire persists.

- Do not wear loose or hanging garments when using the range. They could ignite if they touch a hot surface element and you could be burned.



- Use only dry potholders. Moist or damp potholders on hot surfaces may result in burns from steam. Do not let potholders touch hot heating elements. Do not use a towel or bulky cloth for a potholder. It could catch on fire.
- Keep range vents unobstructed.
- Do not heat unopened containers. They could explode. The hot contents could cause burns and container particles could cause injury.

When using the cooktop

- Coil element cooktop models: Make sure the drip bowls are in place during cooking. Cooking without drip bowls may subject the wiring and components underneath them to damage.
Do not line drip bowls with aluminum foil or other liners. Improper installation of these liners may result in a risk of electric shock or fire.
- Glass ceramic cooktop models: Do not cook on a broken glass ceramic cooktop. If cooktop should break, cleaning solutions and spillovers may penetrate the broken cooktop and create a risk of electrical shock. Contact a qualified technician immediately.

IMPORTANT SAFETY INSTRUCTIONS

- Select a pan with a flat bottom that is about the same size as the surface element. If pan is smaller, some of the heating element will be exposed and may result in the igniting of clothing or potholders. Correct pan size also improves cooking efficiency.
- Check to be sure glass cooking utensils are safe for use on the range. Only certain types of glass, glass ceramic, ceramic, earthenware or other glazed utensils are suitable for cooktops without breaking due to the sudden change in temperature.
- Never leave surface elements unattended at high heat settings. A boilover could result and cause smoking and greasy spillovers that may ignite.
- Do not heat fat quickly and always watch as it heats.



- Turn pan handles inward, but not over other surface elements. This will help reduce the chance of burns, igniting of flammable materials, and spills due to bumping of the pan.

When using the oven

- Always position oven rack(s) in desired location while oven is cool. If a rack must be removed while oven is hot, do not let potholder contact hot heating element in oven.
- Use care when opening oven door. Let hot air or steam escape before removing or replacing food.
- When broiling, place meat at least 3" (7.4cm) from the broil element. Meat placed too close to the element may spatter, smoke, burn or catch fire during broiling.

Grease

- Grease is flammable. Do not allow grease to collect around cooktop or in vent. Wipe spillovers immediately.
- To ensure adequate grease drainage, do not use cookie sheets or similar pans for broiling. Also, covering the broiler grid with foil is not recommended. Poor drainage of grease may result in fire.



- Do not use water on grease fires. Never pick up a flaming pan. Smother flaming pan on range by covering with a well fitted lid, cookie sheet or flat metal tray.

Flaming grease outside of pan can be extinguished with baking soda or, if available, a multi-purpose dry chemical or foam-type extinguisher.

Care and cleaning

- Coil element cooktop models: Do not soak removable coil heating elements in water. The element will be damaged and shock or fire could result.
- Glass ceramic cooktop models:
DO NOT CLEAN HOT GLASS CERAMIC SURFACES. If spills occur, move them aside – **off the hot element** as soon as possible with a razor blade scraper (single edge razor blade in a holder), wearing protective gloves. After the element area is cool to the touch, clean cooktop with Cooktop Polishing Creme, then rinse with a damp paper towel and wipe dry.
- When the self-cleaning cycle is on, the range exterior and cooking surface will become hot. Keep children away from the range as a safety precaution.
- Do not repair or replace any part of the range unless specifically recommended in this manual. All other servicing should be referred to a qualified technician.
- Disconnect the electrical supply before servicing the range.

ELECTRONIC OVEN CONTROL

Electronic Display

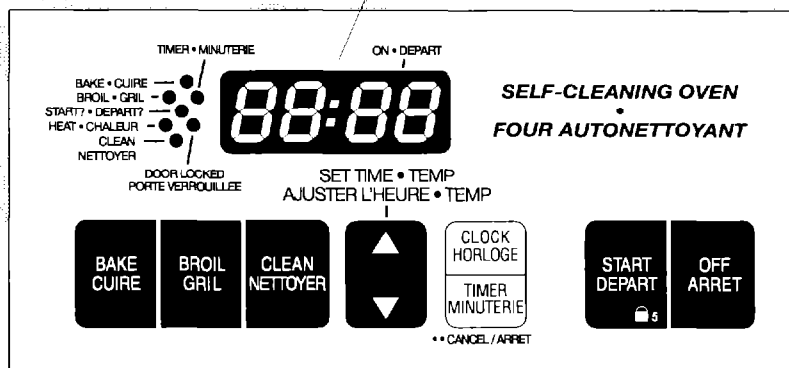

Display/clock

- When you first plug in the range, "PF" will appear on the display until you press any command button. If "PF" again appears on the the display, your electricity was off for a while. You will need to reset the clock and reprogram any temperature adjustments you may have made. See "Setting the clock" on page 7; and "Adjusting oven temperature control" on page 12.
- When you are using the oven, the display will show preheat times and temperature settings.
- When you are not using the self-cleaning function or cooking with the oven, the display will show time of day.
- When setting a function, if you do not press the **START** button within 5 seconds, the START? indicator light will flash. If you do not press the **START** button within 5 minutes, the function will be canceled.

Indicator lights

An indicator light to the left of the display lights up when you are using an oven function, when the oven door is locked, and when the oven is on.

Using the control lock

The control lock lets you disable the control panel command buttons. The control lock comes in handy when you want to prevent others from using the oven.

NOTES :

- You can only use the control lock when the oven is not in use or the control has not been set.
- Set the control lock when cleaning the control panel to prevent yourself from accidentally turning on the oven.
- You must reset the control lock if the power goes out for more than 1 second.

To lock the control panel :

Press and hold the **START** button for 5 seconds.



You will hear a single tone and "Loc" will appear on the display for 5 seconds. "Loc" and "START?" will then appear whenever a command button is pressed.

To unlock the control panel :

Press and hold the **START** button for 5 seconds.



You will hear a single tone and "Loc" and "START?" will disappear from the display.

ELECTRONIC OVEN CONTROL

Setting the clock

1. Press the **CLOCK** button.

PRESS



YOU SEE



2. Set the time.

Press the up ▲ or down ▼ button(s) until the correct time shows on the display.

PRESS



YOU SEE

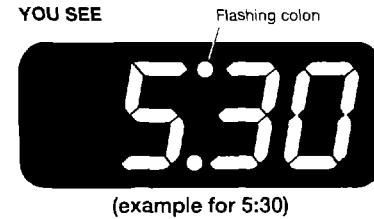

3. Start the clock.

NOTES :

- To see the time of day when it is not on the display, press the **CLOCK** button.
- You must reset the clock if the power goes out for more than 1 second.

PRESS



OR



YOU SEE



ELECTRONIC OVEN CONTROL

Using the minute timer

The minute timer does not start or stop the oven. It works like a kitchen timer. It can be set in hours or minutes up to 12 hours, 59 minutes. The minute timer will display minutes and seconds for settings under 1 hour. You will hear *four* 1-second tones when the set time is up.

1. Press the TIMER button.

PRESS



YOU SEE

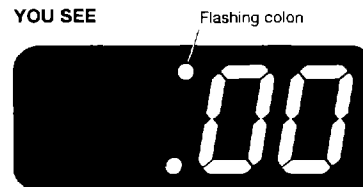

2. Set the countdown time.

PRESS

Press the up ▲ or down ▼ button(s) until the correct time shows on the display.



YOU SEE



(example for 10 minutes)

3. Start the minute timer.

PRESS



OR



YOU SEE



(display counts down)

ELECTRONIC OVEN CONTROL

When time is up :

You will hear four 1-second tones.

NOTE :

- To see the countdown time when the minute timer is not on the display, press the **TIMER** button.

YOU SEE



4. Turn off the minute timer.

PRESS TWICE

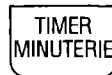

YOU SEE

...previous display

5. To CANCEL the minute timer.

PRESS TWICE



YOU SEE

...previous display

Starting/Canceling a function

PRESS



After setting a function for the first time, you must press the **START** button to start the function.

PRESS



The **OFF** button will cancel any function except the clock, minute timer, and control lock.

ELECTRONIC OVEN CONTROL

Baking & Roasting

1. Place the oven racks where you need them in the oven. For more information, see "Oven rack positions" on page 24.

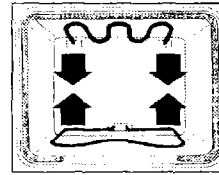
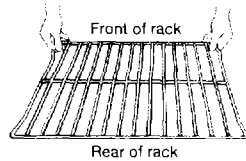

The bottom element operates at full power and the top element cycles whenever preheating. During baking, the top element cycles on and off to provide balanced cooking and even top browning.

Use this setting for baking, roasting and heating casseroles.

2. Choose the baking/roasting setting.

The BAKE indicator light will light up.

PRESS



YOU SEE



3. Set the temperature (optional).

Do this step if you want to set a temperature other than 350°F. Press ▲ to raise the temperature or ▼ to lower the temperature in 5°F amounts. You can set the temperature anywhere from 170°F to 500°F. Use these buttons until the desired temperature is displayed.

PRESS



YOU SEE



(example for bake/roast at 375°F)

4. When roasting or cooking casseroles...

Put your food in the oven.

You do not have to preheat the oven when roasting or cooking casseroles.

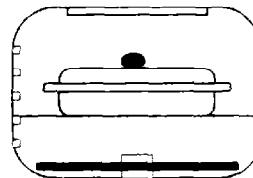

ELECTRONIC OVEN CONTROL

5. Press the START button.

A preheating time will count down on the display. The HEAT and ON indicator lights will light up. The oven control automatically sets preheating time based on the oven temperature you select.

- For 245°F and less, the preheating time is 4 minutes.
- For 250°F-445°F, the preheating time is 10 minutes.
- For 450°F and above, the preheating time is 15 minutes.

When preheating is complete you hear a 1-second tone, the preheat indicator light turns off, and the set temperature is displayed.

NOTES :

- You can change the temperature setting any time after pressing the **START** button. You do not have to press the START button again.
- The preheating time will not change if you reset the temperature before the countdown time ends.
- If you are baking/roasting while the minute timer is counting down, you can see the set baking/roasting temperature for 5 seconds by pressing the **BAKE** button.

PRESS



YOU SEE



(example for set temperature of 350°F)

6. When baking...

Put your food in the oven after the preheat countdown ends.

During baking/roasting the elements will turn on and off to keep the oven temperature at the setting.

NOTE : The top element helps heat during baking/roasting, but does not turn red.

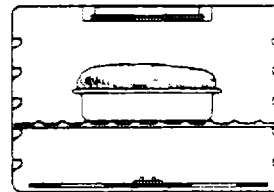

7. After cooking, turn off the oven.

PRESS



YOU SEE

... time of day or
minute timer countdown

ELECTRONIC OVEN CONTROL

Adjusting oven temperature control

Although your new oven is properly adjusted to provide accurate temperatures, it may cook faster or slower than your old oven.

If you are not satisfied with the baking/roasting results, you can change the offset temperature by following the steps below :

NOTE : DO NOT measure the oven temperature with a thermometer. Opening the oven door will lower the oven temperature and give you an incorrect reading. Also, the thermometer temperature will change as your oven cycles.

1. Press and hold **BAKE** for 4 seconds.

The display will show 350°F for 4 seconds. Then it will show the current offset temperature, for example "00", if you have not already adjusted the temperature.

PRESS



YOU SEE

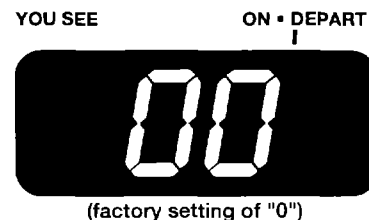

2. Set the new offset temperature.

Press ▲ to raise the temperature or ▼ to lower the temperature in 10°F amounts. You can set the temperature change as low as -30°F or as high as +30°F. A minus (-) sign will appear before the number when decreasing the temperature setting. The minus sign indicates that the oven will be cooler by the displayed amount. There is no sign in front of the number when increasing the temperature setting.

PRESS



YOU SEE

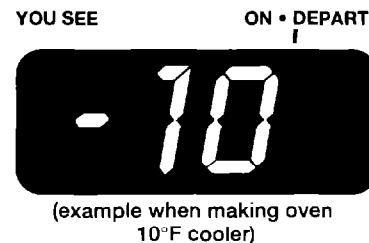

3. Enter the adjustment.

NOTE : The offset temperature resets to "00" if the power goes out for more than 1 second.

PRESS



YOU SEE

... time of day or
minute timer countdown

ELECTRONIC OVEN CONTROL

How to determine the amount of temperature adjustment needed...

The chart at the right tells you how much to adjust the offset temperature to get the cooking results you want. You can figure out cooking results by the amount of browning, moistness, and rising times for baked foods.

To Cook Food...	Adjust by this Number of Degrees °F
a little more	+10
moderately more	+20
much more	+30
a little less	-10
moderately less	-20
much less	-30

ELECTRONIC OVEN CONTROL

Broiling

NOTES :

- Do not preheat when broiling.
- Leave the door partly open when you use the oven to broil. This lets the oven stay at the proper temperatures.

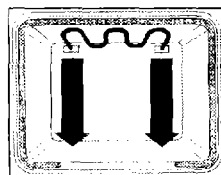

The top element (as set by the Broil function) operates at full power when heating.

Use this setting for normal broiling and top browning with the door open in the Broil Stop position.

This setting can also be used for Vari-Broil with the door closed. The element will cycle off and on to maintain the preset temperature.

1. Place the oven rack for broiling.

Place the oven rack so that the surface of the food is at least 3" (7.5 cm) away from the broil element. For more information, see "Broiling" on page 23.

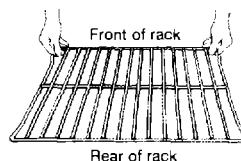

2. Place your food on the broiler pan and place the pan in the center of the oven rack.

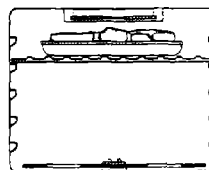

3. Close the oven door to the broil stop position.

The broil stop position lets the door stay open about 4" (10 cm) by itself.

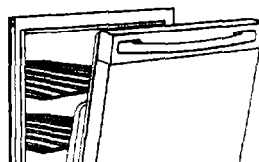

ELECTRONIC OVEN CONTROL

4. Press the BROIL button.

The broil indicator light will light up.

PRESS



YOU SEE



(500°F standard broiling temperature)

5. Start broiling.

The ON and HEAT indicator lights will light up.

NOTES :

- You can change the temperature setting any time after pressing the **START** button. To change the setting, see "Vari-Broil" on the next page. After changing the setting, you do not have to press the **START** button again.
- If you are broiling while the minute timer is counting down, you can see the set broiling temperature for 5 seconds by pressing the **BROIL** button.

PRESS



YOU SEE



6. After broiling, turn off the oven.

PRESS



YOU SEE

... time of day or
minute timer countdown

ELECTRONIC OVEN CONTROL

Vari-Broil

To custom broil at a lower temperature...

- **If the food is cooking too fast...**

Press the **BROIL** button and press the **▼** button until "325°F" shows on the display. After changing the setting, you do not have to press the **START** button again.

PRESS



YOU SEE

ON • DEPART



(example for broiling at 325°F)

- **If you want food to broil slower from the start...**

Close the oven door.

Press the **BROIL** button and press the **▼** button so a temperature between "300°F" and "500°F" shows on the display.

Press the **START** button.

Lower temperature settings let the broil heating element cycle and slow cooking down. The lower the temperature, the slower the cooking.

NOTE : Fish and chicken are some foods that may cook better if you use lower broiling temperatures.

PRESS



YOU SEE

ON • DEPART



(example for broiling at 400°F)

ADDITIONAL RANGE FEATURES

Oven vent

Coil element cooktop models:

Hot air and moisture escape from the oven through a vent under the left rear surface element. You can cook on the element or keep food warm on it while the oven is on.

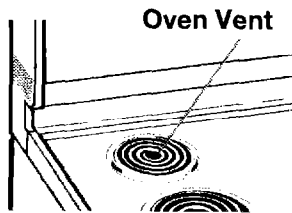

WARNING

Burn Hazard

- If you leave a utensil on the left rear surface element, use potholders when moving it. Pan handles can become hot enough to burn.
- Plastic utensils left over the vent can melt.

Glass ceramic cooktop models:

The oven vent, located on the lower left side of the backguard, allows hot air and moisture to escape when the oven is in use.

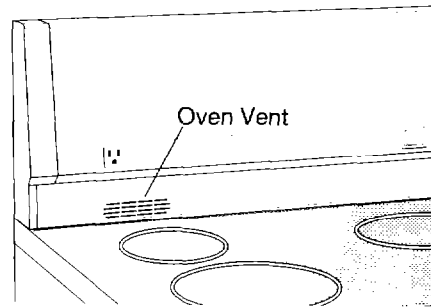

Do not block the vent.

Poor baking/roasting may result

Use warm soapy water to clean the vent.

Broiler pan storage rack

(on some models)

A handy rack has been designed at the top of the storage drawer to hold the **broiler pan** and **broiler pan grid**.

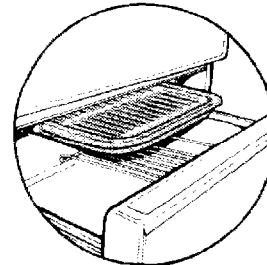

ADDITIONAL RANGE FEATURES

Automatic oven light

The oven light will turn on automatically once the oven door is opened and will remain on while the door is open. Since it functions separately from the electronic range control, the oven does not need to be on for the light to come on.

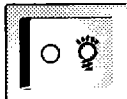

The oven light may also be turned on using the manual switch located on the control console.

Fluorescent cooktop light

(on some models)

The cooktop light is in the top of the control console.

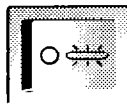

The switch is on the control console. Push the switch to turn the light on. The light may take a few seconds to light up.

Appliance outlet

(on some models)

The 120v appliance outlet located on the control console may be used to run portable appliances placed on a counter top beside the range.



The outlet operates independently and is not affected by range control settings

WARNING

Fire Hazard

- Do not place appliances on the cooktop. A fire could result if the cooktop is hot or someone turns it on.

USING THE SURFACE ELEMENTS

Surface element controls

Control knobs must be pushed in before turning them to a setting. They can be set anywhere between HI and "0" (OFF).

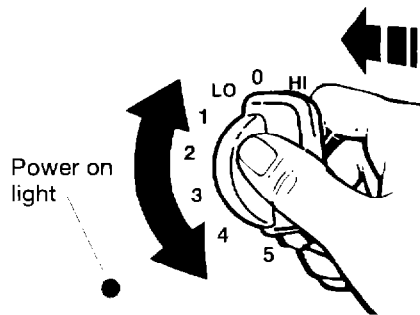

The controls for the surface elements provide infinite heat settings. The numbers on the dial serve as a reference. The control can be turned to any setting to provide the exact heat required.

Glass ceramic cooktop models: The controls work on the principle of percent on, percent off. For example, when the control is turned to the "5" setting, the element will be on only 50% of the time. Because of the fast heat-up of radiant heat elements, you will notice, and perhaps even hear, the element switching on and off.

Power on lights

The Power On lights beside the control knobs indicate which surface elements are turned on by the knobs. A Power On light will glow when its associated surface element is turned on.

WARNING

Burn and Fire Hazard

- Be sure all control knobs are turned to "0" and the Power On light(s) is off when you are not cooking.
- Someone could be burned or a fire could start if a surface element is accidentally left ON.

Control setting guide

Until you get used to the settings, use the following chart as a guide.

For best results, start cooking at the high settings; then turn the control knob to a lower setting to continue cooking.

SETTING	RECOMMENDED USE
HI	<ul style="list-style-type: none">• To start foods cooking.• To bring liquids to a boil.
8-7	<ul style="list-style-type: none">• To hold a rapid boil.
6-5	<ul style="list-style-type: none">• To fry foods.
4	<ul style="list-style-type: none">• For gravy, pudding and icing.• To cook large amounts of vegetables.
3-2	<ul style="list-style-type: none">• To keep food cooking after starting it on a higher setting.
1	<ul style="list-style-type: none">• To keep foods warm until ready to serve

USING THE SURFACE ELEMENTS

Coil element cooktop models:

CAUTION

The temperature of the cooktop surface increases with the number of elements that are on. With 3 or 4 elements turned on, surface temperatures are high and caution should be exercised when around the cooktop.

- Drip bowls should be used at all times. Do not use aluminum foil to cover drip bowls. Use of aluminum foil could result in a shock hazard, improper cooking, or damage to the element.
- Prolonged use of elements without pots can cause damage and early failure.
- Use of round bottom woks is not recommended.

See pages 31 and 32 for care and cleaning instructions

Simmer element (on some models)

Identified on the disc in the centre of the element, this element can maintain lower temperatures for preparation of foods which require very low heat (e.g. sauces, chocolate, cheese).

Glass ceramic cooktop models:

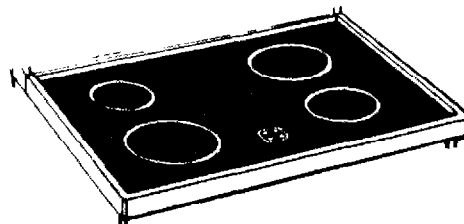

Glass ceramic cooktop elements

Quick light radiant heating elements

The quick light radiant heating elements are designed for *fast* heat response. You can see them light up in just seconds.

These elements consist of a set of special heater coils embedded in a thermal insulation material. Each element is fitted with a thermal limiter to ensure the glass ceramic does not exceed the maximum safe operating temperature specified by the glass ceramic manufacturer. You may notice the element going on and off a number of times during use. This is a normal occurrence.

To maximize the efficiency of this type of heater, we suggest you use it similarly to your previous element type. Turn to maximum until the desired temperature is reached, then turn it down to the setting that best maintains the desired heat.

NOTE: 1. Sliding metal pans on the glass ceramic cooktop surface may leave marks. If the elements are not hot, metal marks can be removed using Cooktop Polishing Creme. Other marks may be permanent. Wiping off the cooktop after each use will eliminate stains and provide the most even heating.

2. Using a pan with a nicked or scratched bottom may damage the glass ceramic cooktop. Heating a soiled pan may leave a stain on the cooktop.

See pages 33 and 34 for care and cleaning suggestions.

Hot surface indicator lights

Single hot surface indicator light (on some models)



The Hot Surface indicator light on the cooktop surface will glow when the surface elements are turned on. The Hot Surface indicator light will continue to glow as long as the elements are too hot to touch, even after they are turned off.

Four hot surface indicator lights (on other models)

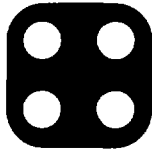

The Hot Surface indicator lights on the cooktop surface will glow when their corresponding surface elements are turned on. The Hot Surface indicator lights will continue to glow as long as the elements are too hot to touch, even after they are turned off.

NOTE : Heat from the oven vent may cause the left rear Hot Surface indicator light to glow as a warning that the area is warm to touch.

COOKWARE

Cookware

There is no one brand of cookware that is best. Knowing something about cookware materials and construction will help you select the correct cookware for your needs.

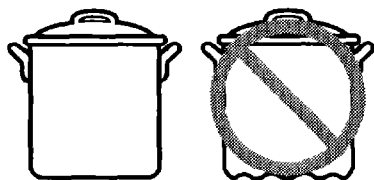

- Use only flat-bottomed cookware that makes good contact with the surface elements. To check the flatness of a piece of cookware:
 - Turn it over and check the bottom of the pan by placing a ruler across it.
 - Rotate the ruler in all directions. The bottom should be slightly concave.
- NOTE:** Woks, canners and teakettles with flat bottoms suitable for use on your cooktop are now available in most houseware or department stores.
- Cookware should have tight-fitting lids.
 - Choose medium to heavy gauge (thickness) cookware for best results.
 - Use cookware that closely matches the diameter of the heating element, for most efficient cooking.
 - Handles should be made of sturdy, heat-resistant material and be securely attached to the cookware.

Home canning information

Most canners have a much larger bottom diameter than the cooktop elements. Canners can be used as long as they have straight sides, are heavy gauged, have flat bottoms and do not exceed the diameter of the surface element by more than 1"-1¹/₂" (2.5-3.7 cm) on any side.

Alternate use of surface elements between batches to allow elements to cool down.



WARNING

Burn, Personal Injury and Product Damage Hazard

- Prolonged usage of incorrect cookware for long periods of time can result in damage to the surface element, cooktop, wiring and surrounding areas. To prevent damage, use correct cookware, start cooking on HI and turn control down to continue cooking.
- Do not leave empty cookware, or one which has boiled dry, on a hot surface element. It can overheat and may damage the cookware or surface element.
- Do not use canners, woks and specialty cookware with rounded, warped, ridged or dented bottoms. These could cause severe overheating which damages the cookware and/or surface elements.

Broiling

1. **Open the door to the Broil Stop position (open about 4" [10 cm]).**
2. **Use the broiler pan and grid for broiling.**
They are designed to drain excess liquid and fat away from the cooking surface to help prevent spatter, smoke and fire.
3. Place food on a cold pan to prevent sticking. If the rack is hot, grease it or grease the food.
4. The surface of the food should be at least 3" (7.4 cm) away from the broil element.
5. Turn food only once during broiling. Using tongs to turn meats prevents loss of juices. Use the MINUTE TIMER for timing each side.
6. For steaks and chops, slash fat evenly, at 2" (5 cm) intervals, around the outside edges of meat to prevent curling.
7. Meats and poultry can be marinated before broiling. Brush foods with barbecue sauce only during the last 5 to 10 minutes of broiling.

	UTENSIL	OVEN CONTROL SETTING
Broiler pan		BROIL BAKE
Broiler pan grid		BROIL BAKE

COOKING TIPS

Air circulation

The hot air must circulate around the pans in the oven for even heat to reach all parts of the oven. This results in better baking.

For best air circulation:

- Place the pans so that one is not directly over the other.
- For best results, allow 1 $\frac{1}{2}$ " to 2" (3.7-5 cm) of space around each pan and between pans and oven walls. There must be a minimum space of 1" (2.6 cm).



- When baking with one pan, place pan in the center of the oven rack.
- When baking with two pans, place pans in opposite corners of the oven rack.

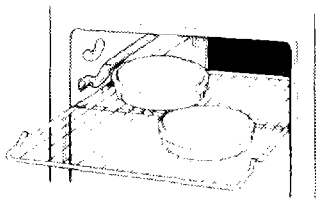

NOTE: Opening the oven door may cause heat loss, longer cooking times and unsatisfactory baking or roasting results. Rely on your timer.

Oven rack positions

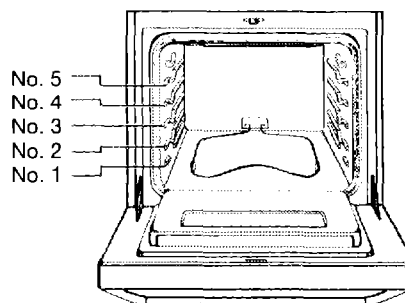

Your oven has five rack positions. Rack position 1 is the lowest position, or closest to the bottom of the oven. Rack position 5 is the highest position, or farthest from the bottom of the oven.

WARNING

Fire and Personal Injury Hazard

- Always position oven rack(s) in desired location before turning oven on. Be sure the rack(s) is level.
- If rack(s) must be moved while oven is hot, use potholders or oven mitts to protect hands.
- Do not let potholders or oven mitts come in contact with hot heating elements.
- Always use a dry potholder or oven mitt to change rack(s) or handle utensils in the oven. Do not use a damp potholder or oven mitt. Steam burns could result.

Failure to follow the above precautions may result in fire or personal injury.

COOKING TIPS

There are two straight racks. Be sure to position the oven rack(s) before putting food into the oven or turning the oven on.

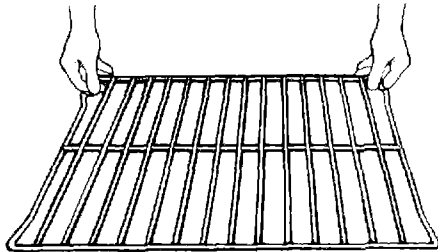

Rear of rack

To remove oven racks:

Lift rack at front and pull out.

To replace oven racks:

1. Place rear of rack on rack guides.
2. While lifting front of rack, push in all the way. Lower front.

For Proper Cooking, Follow These Guidelines:

- **When using one rack**, place the rack so the **top of the food** will be centered in the oven.
- **When using two racks**, place racks in positions 3 and 1 (the closest to the oven bottom).
- **Use only one cookie sheet** in the oven at a time when using the Bake setting.

Rack Placement For Specific Foods:

(For rack positions, see "Rack Positions" on page 24).

FOOD	RACK POSITION
Frozen pies	1 or 2
Angel and bundt cakes, most quick breads, yeast breads, casseroles, meats	2
Cookies, biscuits, muffins, cakes, non frozen pies	2 or 3

COOKING TIPS

Using Aluminum Foil In The Oven

WARNING

Electrical Shock and Fire Hazard

- Do not allow foil to touch the heating elements because it will damage them and could result in electrical shock or fire hazard.

Do not cover the broiler grid with foil. Poor drainage of grease may result in a fire.

When using aluminum foil to catch spillovers from pies or casseroles, follow these instructions:

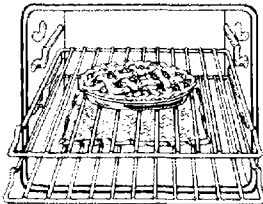

- **Place the foil on the oven rack below the rack with the food.** Turn foil edges up and make sure foil is about 1 inch (2.5 cm) larger all around than the dish holding the food.
- **Do not cover the entire rack** with aluminum foil. It will reduce air circulation and cause poor cooking results.
- **Do not line oven bottom** or entire oven rack with foil or other liners. Poor baking will result.

OVEN SELF-CLEANING CYCLE

The self-cleaning cycle operates with the easy-to-use electronic control. To use this cycle properly, follow the step-by-step instructions in this section.

How the self-cleaning cycle works

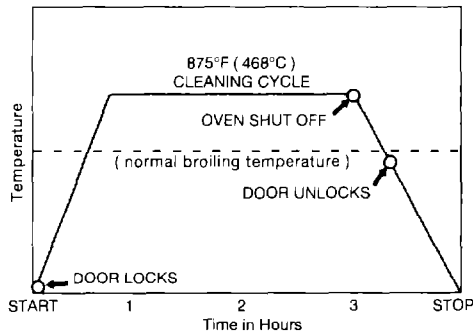

The self-cleaning cycle uses very high heat to burn away soil and grease. During the cycle, the oven gets much hotter than it does for normal baking or broiling - approximately 875°F (468°C). This high heat breaks up the soil or grease and burns it away.

Your oven is preset for a 3¹/₂ hour self-cleaning cycle. However, the cycle time can be adjusted to the amount of soil in your oven.

The graph above is representative of a 3-hour self-cleaning cycle. Note that the heating stops when the 3-hour setting is up, but it takes longer for the oven to cool enough to unlock the oven door.

Before you start

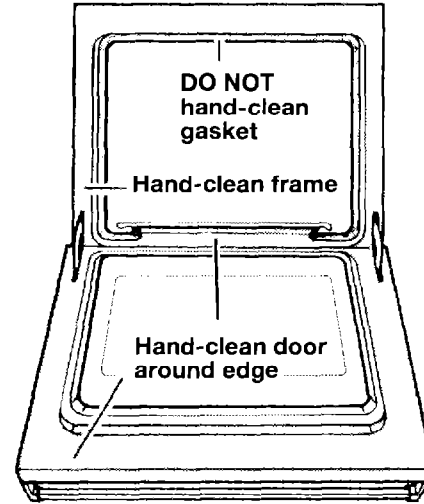

Before you start the self-cleaning cycle, make sure you:

- **Hand-clean** the areas shown. They do not get hot enough during the cleaning cycle for soil to burn away, and could get baked on during cleaning. Use hot water and detergent or a soapy steel-wool pad for cleaning.

NOTE: DO NOT clean, move or bend the gasket. Poor cleaning, baking and roasting may result.

- **Wipe out** any loose soil or grease. This will help reduce smoke during the cleaning cycle.
- **Remove** any combustible items (such as paper napkins) from the storage drawer. This includes utensils with plastic handles that can become overheated and melt.

OVEN SELF-CLEANING CYCLE

- **Remove** the broiler pan grid and anything else being stored in the oven.

NOTE: The broiler pan and grid can be cleaned in the oven if most of the soil is removed first by hand-cleaning or a dishwasher. If most of the soil is not removed, excessive smoking will occur.

- **Remove** food from the cooktop which could be affected by heat during the self-cleaning cycle.
- **Remove** the oven racks from the oven if you want them to remain shiny and easy to slide.

NOTE: If oven racks are cleaned in the self-cleaning cycle, they will become discolored and more difficult to slide.

If you clean racks in the self-cleaning cycle, place them on the 2nd, 3rd and 4th rack guides.

- **Check** to see that the oven door is closed tightly on all sides.
- **DO NOT put drip bowls from coil element cooktops in oven during self-clean cycle because damage to the finish can occur.**

For best cleaning results

- **Clean the oven before** it gets heavily soiled. Cleaning a very soiled oven takes longer and results in more smoke than usual.
- **After the oven is cool, wipe up** any residue or ash with a damp cloth or sponge. If any spots remain, clean with a mild abrasive cleanser or mildly abrasive pad.
- **If the self-cleaning cycle does not get the oven as clean as you expected**, the cycle may not have been set long enough or you may not have prepared the oven properly. Set the self-cleaning cycle longer the next time and hand-clean areas noted above.

Automatic door lock

As soon as you program the oven for the self-cleaning function, the door will automatically lock. It will remain locked throughout the entire cycle. The door will automatically unlock when the temperature lowers to a safe level.

WARNING

Personal Injury and Product Damage Hazard

- **Be sure** that the oven door is properly aligned and closed tightly on all sides.
- **Do not touch the oven** or use the surface elements during the self-cleaning cycle. They could burn you.
- **Do not use commercial oven cleaners** in your self-cleaning oven. Cleaners may produce hazardous fumes or damage the porcelain finish.
- **Remove foil or other liners from the oven.** During the self-cleaning cycle, foil can burn or melt and damage the oven surface.
- **Do not leave plastic utensils near the vent.** They may melt.
- **Do not block the vent** during the self-cleaning cycle. Air must move freely for best cleaning results.
- **Heat and odors** are normal during the self-cleaning cycle. Keep the kitchen well ventilated by opening a window or by turning on a vent hood or other kitchen vent during the cycle.

OVEN SELF-CLEANING CYCLE

Setting the controls

1. Press the **CLEAN** button.

The CLEAN indicator light will light up.

The control will automatically set a 3¹/₂ hour Self-Cleaning cycle.

NOTE : There will be a 30 minute cool down ¹/₂ hour before the cycle is over.

PRESS



YOU SEE



2. Set the cleaning time (optional).

If you want a Self-Cleaning cycle longer or shorter than 3¹/₂ hours, use the SET TIME buttons to set the cleaning time you want. Press the up ▲ or ▼ down button(s) to set a time between 2¹/₂ - 4¹/₂ hours on the display.

- Use 2¹/₂ hours for light soil.
- Use 3¹/₂ - 4¹/₂ hours for average to heavy soil.

PRESS



YOU SEE

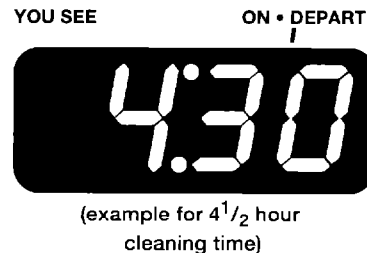

3. Start the self cleaning cycle.

The oven door will lock and the DOOR LOCKED, ON, and HEAT indicator lights will light up.

NOTE : If you open the oven door before starting the Self-Cleaning cycle, "door" will show on the display. If you do not close the door within 5 minutes the Self-Cleaning cycle will be canceled.

PRESS



YOU SEE



OVEN SELF-CLEANING CYCLE

4. **When the Self-Cleaning cycle ends and the oven has cooled down...**

The CLEAN, DOOR LOCKED, and ON indicator lights will go out and the door will unlock.

Press the **OFF** button to clear the display.

PRESS



YOU SEE



5. **After the oven is cool, wipe off any residue or ash with a damp cloth or sponge**

If needed, remove spots with a mild abrasive cleanser or cleaning sponge.

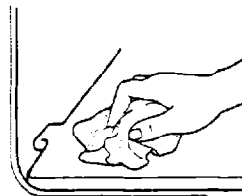

To stop the self-cleaning cycle at any time...

If the oven temperature is above normal broiling temperature, the Self-Cleaning cycle will start a 30 minute cool down. The CLEAN and DOOR LOCKED indicator lights will stay on.

PRESS



YOU SEE

ON • DEPART



After the oven cools :

YOU SEE



WARNING

Burn and Electrical Shock Hazard

- Make sure all controls are OFF and the range is cool before cleaning. Failure to do so can result in burns or electrical shock.

Your range is designed for ease of cleaning. Most cleaning can be done with soap and water or other mild household cleaners. Cleaning your range whenever spills or soiling occurs will keep it looking and operating like new.

DO NOT use commercial oven cleaners on the exterior, including door frame.

Coil element removal/replacement

The coil elements are self-cleaning. Any spillage will burn off. However, removal of large pieces of food or excess oil is recommended to prevent smoking.

DO NOT IMMERSE COIL ELEMENTS IN WATER

NOTE:

Drip bowls reflect heat back to cookware placed on the coil elements. They also help catch spills. When they are kept clean, they reflect heat better and look new longer.

Removing a coil element

1. Make sure all coil elements are turned off and cool before removing coil elements and drip bowls.
2. Lift the edge of the element, opposite the receptacle, just enough to clear the drip bowl.

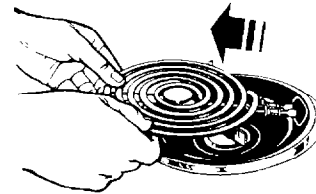

3. Pull the element straight away from the receptacle.
4. Lift out the drip bowl.



COIL ELEMENT COOKTOP MODELS

CARING FOR YOUR RANGE

Replacing a coil element

1. Make sure all coil elements are turned off before replacing elements and drip bowls.
2. Line up openings in the drip bowl with the coil element receptacle.
3. Hold the element as level as possible with the terminal just started into the receptacle. Gently push the element terminal into the receptacle.

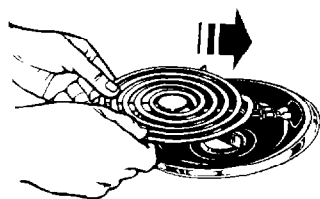

4. When terminal is pushed into the receptacle as far as it will go, push down the edge of the element opposite the receptacle.

Lift-up cooktop (on some models)

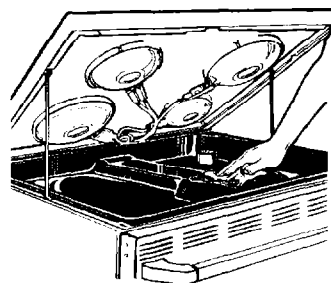

1. Lift front of cooktop at both front corners until the support rods lock into place.
2. Wipe with warm, soapy water. Use a soapy steel-wool pad on heavily soiled areas.
3. To lower the cooktop, lift cooktop from both sides while pressing the support rods back to unlock them. Lower the cooktop into place.

WARNING

Personal Injury and Product Damage Hazard

- All Surface elements must be turned off before lifting the top.
- Make sure the cooktop is cool to touch before lifting.
- Be sure both support rods are fully extended and in the locked position. Failure to do so could result in personal injury from the cooktop accidentally falling.
- Do not drop the cooktop. Damage can result to the porcelain and the cooktop frame.
- Be cautious of loose wires when cleaning .

Your range is designed for ease of cleaning. Most cleaning can be done with soap and water or other mild household cleaners. Cleaning your range whenever spills or soiling occurs will keep it looking and operating like new.

DO NOT use commercial oven cleaners on the exterior, including door frame.

The glass ceramic cooktop is designed for easy care. However, glass ceramic cooktops need to be maintained differently than standard electric open-coil elements. Foods spilled directly on the cooktop will not burn off as on open-coil elements. Because of this, the surface should be dust-free and soil-free before heating.

Cooktop Polishing Creme, paper towels or a clean cloth, and a razor blade scraper is all you need to clean your cooktop .

Your cooktop has been prepolished at the factory for improved protection and cleanability. For proper cleaning methods, please review "Cleaning tips" page 34. Follow them after each use to ensure top performance and to preserve the uniquely elegant look.

WARNING

Personal Injury Hazard

- **To remove spills from hot elements:**
Turn OFF the element. Move spills away from the element area with a razor blade scraper. Wear protective clothing such as oven mitts. Clean element with Cooktop Polishing Creme after it has cooled down.
- Do not use cooktop cleaner on a hot cooktop. The cleaner may produce hazardous fumes or damage the cooktop.
- Do not use the range if the cooktop is cracked or broken.

Failure to follow these instructions can result in personal injury.

To avoid damaging the cooktop, follow these instructions:

- **Remove heavy or sugary spills IMMEDIATELY from hot elements following the procedure given above.**
- Do not allow anything that may melt (such as plastic, aluminum foil) to come in contact with the surface while it is hot.
- **DO NOT USE THE COOKTOP AS A CUTTING BOARD.**
- Do not use steel wool, abrasive powdered cleansers, abrasive cleaning pads, chlorine bleach, rust remover, ammonia or glass cleaning products with ammonia. These could damage the cooktop surface.
- Dropping heavy or hard objects on the cooktop can crack it. Be careful with heavy skillets. Do not store jars or cans above the cooktop.

Cleaning tips

What to use:

- **Cooktop Polishing Creme with paper towel or clean, damp cloth.**
This creme has been developed especially for cleaning and protecting your cooktop. When using, follow instructions on container.
- **Razor blade scraper (single edge razor blade in a holder)**
Use to remove cooked-on soils from your ceramic cooktop. Razor blades will not scratch your cooktop. Store razor blades out of reach of children.

Steps to follow:

1. Most spills can be wiped off easily using a paper towel or clean, damp cloth as soon as Hot Surface indicator light(s) go off.
2. Carefully scrape off any burnt-on food with a razor blade scraper.
3. Rub Cooktop Polishing Creme into cooked-on soil using a paper towel. If some soil remains, leave some creme on the spot(s) and follow Step 2.
4. Finish by polishing entire cooktop with Cooktop Polishing Creme and a paper towel.

Additional tips:

- **Sugar spills and soils** (such as jellies and candy syrups) can cause pitting on the cooktop if not removed while the ceramic surface is still hot. Remove as soon as possible after the spill occurs with a razor blade scraper.
- **Remove dark streaks, specks and discoloration** with Cooktop Polishing Creme after the cooktop has cooled.

- **Remove metal marks** (from copper or aluminum pans) with Cooktop Polishing Creme before heating the cooktop again. If heated before cleaning, metal marks may not come off.
- **Tiny scratches or abrasions do not affect cooking.** In time, these will become less visible as a result of regular use of Cooktop Polishing Creme.
- **Make sure bottoms** of pans are clean and dry before using.
- **Avoid spillovers.** Use pans with tall sides.
- **Do not** cook food directly on glass ceramic cooktop.

Cooktop Polishing Creme can be purchased through authorized service centres or major department stores.

Removable oven door

The oven door is removable to allow easier cleaning inside the oven. The door will stand supported by its hinges.

Removing the oven door:

1. Open the door to the Broil Stop position (open about 4" [10 cm]).
2. Lift door slightly and pull out and back until hinges come out to the catch position.
3. Push door down and pull straight out to remove door completely.

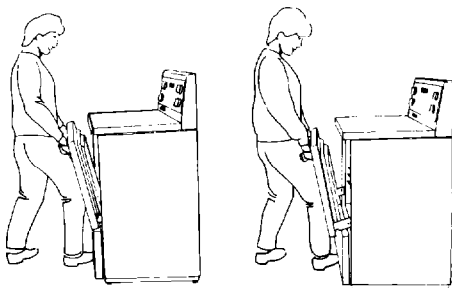

Replacing the oven door:

1. Holding the door by the handle, place the top of the door under the cooktop overhang and use your leg to apply pressure to slide hinges into the slots as far as possible.
2. Open door to the broil position or slightly past it.
3. Using the side of your leg, apply pressure to the bottom of the door front. Lift the door slightly while applying pressure to push, until the hinges have gone in fully.

If top of door rubs on cooktop overhang, remove door and re-install.

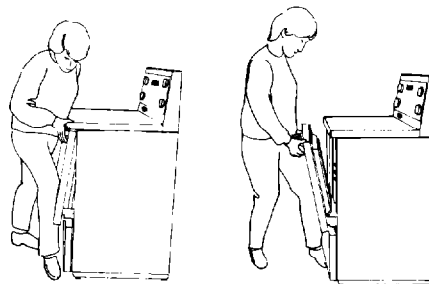

CONVENIENT CLEANING FEATURES

CARING FOR YOUR RANGE

Sweep-through base

The sweep-through base is designed to allow easy cleaning under the range. It also allows better access to the levelling legs once the range has been set in place.

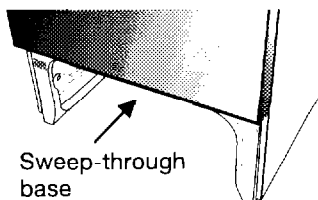

To sweep underneath the range, simply remove the storage drawer (see Installation Instructions sheet for instructions on removing the storage drawer).

Removable control console glass

The control console glass can be removed to allow easy cleaning of both sides of the glass and the control panel.

Use a sponge with warm, soapy water. Do not clean the electronics behind the glass. Liquids can damage the electronics.

To remove the control console glass:

1. Remove surface element control knobs by pulling them straight off.
2. Lift the cover on top of the control console and remove the fluorescent lamp (see instructions, page 39).
3. Remove the control console glass by pulling it slightly forward and straight up.

PART	WHAT TO USE	HOW TO CLEAN
Glass ceramic cooktop (on glass ceramic cooktop models)		<ul style="list-style-type: none"> • See pages 33-34 for cleaning instructions.
Oven cavity	Self-cleaning cycle	<ul style="list-style-type: none"> • See "Oven Self-Cleaning Cycle" on pages 27-30.
Control knobs	Soft sponge and warm, soapy water	<ul style="list-style-type: none"> • Turn knobs to OFF and pull straight away from control panel. • Wash, rinse and dry thoroughly. Do not soak. • Replace knobs. Make sure all knobs point to OFF. <p>DO NOT USE steel wool or abrasive cleaners. They may damage the finish.</p>
Control console glass (on models with glass control console)	Soft sponge and warm, soapy water OR Paper towel and spray glass cleaner	<ul style="list-style-type: none"> • Wash, rinse and dry thoroughly. <p>DO NOT USE steel wool or abrasive cleaners. They may damage the finish.</p>
Exterior surfaces (other than control console glass and ceramic cooktop)	Soft sponge and warm, soapy water	<ul style="list-style-type: none"> • Wash, rinse and dry thoroughly. USE non-abrasive, plastic scrubbing pad on heavily soiled areas. • Do not use abrasive or harsh cleansers.
Coil elements (on coil element cooktop models)	No cleaning required	<ul style="list-style-type: none"> • Spatters and spills will burn off. • Do not immerse in water.
Porcelain-enamel drip bowls (on coil element cooktop models)	Non-abrasive or mildly abrasive liquid kitchen cleanser	<ul style="list-style-type: none"> • Wipe off excess spills. • Wash, rinse and dry thoroughly.
Front door vent and handle	Non-abrasive cleaner	<ul style="list-style-type: none"> • Use non-abrasive cleaner to remove stains.
Broiler pan and grid (clean after each use)	Steel-wool pad and warm, soapy water OR Self-cleaning cycle	<ul style="list-style-type: none"> • Wash, rinse and dry thoroughly. <p style="text-align: center;">OR</p> <ul style="list-style-type: none"> • Leave in oven during self-cleaning cycle (see note on page 28).

CLEANING CHART

CARING FOR YOUR RANGE

PART	WHAT TO USE	HOW TO CLEAN
Oven racks	Steel-wool pad and warm, soapy water OR Self-cleaning cycle	<ul style="list-style-type: none">• Wash, rinse and dry thoroughly. OR <ul style="list-style-type: none">• Leave in oven during self-cleaning cycle. <p>NOTE: Racks will discolor and become harder to slide. Apply a small amount of vegetable oil to the side rungs to aid sliding.</p>
Oven window glass	Paper towel and spray glass cleaner OR Warm, soapy water and a non-abrasive, plastic scrubbing pad	<ul style="list-style-type: none">• Make sure oven is cool.• Follow directions provided with the cleaner.• Wash, rinse and dry thoroughly.

Cooktop light replacement

(on models with fluorescent light)

The cooktop light is in the top of the control console. The switch is on the control console. Push the switch to turn the light on. The light may take a few seconds to light up.

WARNING

Electrical Shock Hazard

- Make sure power to the range has been turned OFF at the main power supply before replacing the fluorescent tube.
- Failure to do so could result in electrical shock.

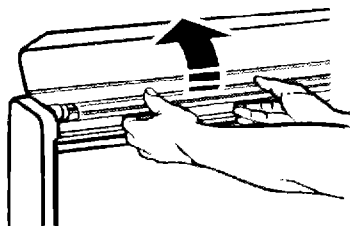

To replace the fluorescent light tube:

1. Turn power off.
2. Lift the cover on top of the control console by lifting the front edge at both ends.
3. Grasp the fluorescent tube at both ends.
4. Turn the tube 90 degrees and lift out of the receptacle.
5. Replace with an F1 8T8 type fluorescent tube.
6. Rotate the tube back by 90 degrees to the original position.

Oven light replacement

The oven light will come on when you open the oven door.

To turn the light on when the oven door is closed, push the oven light switch on the control console. Push the switch again to turn off the light.

WARNING

Electrical Shock and Personal Injury Hazard

- Make sure oven and light bulb are cool and power to the range has been turned off before replacing the light bulb. Failure to do so could result in electrical shock or burns.
- The bulb cover must be in place when using the oven. The cover protects the bulb from breaking, and from high oven temperatures. Because the bulb cover is made of glass, be careful not to drop it. Broken glass could cause injury.

To replace the oven light:

1. Unplug appliance or disconnect at the main power supply.

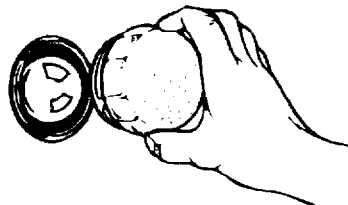

REPLACING LIGHT BULBS & RESETTING BREAKERS

CARING FOR YOUR RANGE

2. Remove the glass bulb cover in the back of the oven by screwing it out counterclockwise.
3. Remove the light bulb from its socket. Replace the bulb with a 40-watt appliance bulb.
4. Replace the bulb cover by screwing it in clockwise. Plug in appliance or reconnect at the main power supply.

NOTE: The oven light will not work during the self-cleaning cycle.

Appliance outlet circuit breaker (on some models)

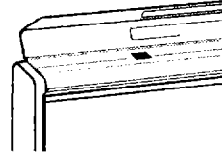

The circuit breaker for the appliance outlet on your range is located under the cover on top of the control console. It is rated for 12 amps. Lift the cover by lifting the front edge at both ends.

On models equipped with a fluorescent cooktop light, remove the fluorescent tube (see instructions on page 39) to gain access to the circuit breaker.

IF YOU NEED ASSISTANCE OR SERVICE

TROUBLESHOOTING

This section is designed to help you save the cost of a service call. However, you may still need assistance or service. When calling for service, you will need to provide a complete description of the problem, your appliance's complete model and serial numbers and the purchase or installation date (see page 2). This information is needed to properly respond to your request.

Before calling for service ...

If your range should fail to operate, review the following list before calling for service. You could save the cost of a service call.

PROBLEM	CHECK IF	WHAT TO DO
Nothing will operate.	The power cord is plugged into a live circuit with proper voltage.	Plug the power cord into a live circuit with proper voltage.
	A household fuse has blown or a circuit breaker has tripped.	Replace household fuse or reset circuit breaker.
The oven will not operate.	The electronic controls have been set correctly.	Refer to instructions for setting the electronic controls starting on page 6.
	A delayed start time has been programmed.	Wait for the start time to be reached.
	A household fuse has blown or a circuit breaker has tripped.	Replace household fuse or reset circuit breaker.
The surface elements will not operate.	A household fuse has blown or a circuit breaker has tripped.	Replace household fuse or reset circuit breaker.
	The control knobs are set correctly.	Push control knobs in before turning to a setting.
The appliance outlet will not operate	The range appliance outlet circuit breaker has tripped.	Reset the circuit breaker (see page 40).
	A household fuse has blown or a circuit breaker has tripped.	Replace household fuse or reset circuit breaker.
Control knobs will not turn.	You are pushing in before turning.	Push control knobs in before turning to a setting.
The self-cleaning cycle will not operate.	If you pressed the start button.	Press the start button.
	The oven door is not closed all the way.	Press the door closed.

TROUBLESHOOTING

IF YOU NEED ASSISTANCE OR SERVICE

PROBLEM	CHECK IF	WHAT TO DO
The display is showing "PF".	There has been a power failure.	Press the OFF pad to clear the display, then reset the clock (see page 7).
"F" followed by a number shows on the display.		Press the OFF pad to clear the display. If an "F" code appears again, call for service.
An indicator light is flashing.		The function indicated may not be working. Refer to the section of this manual which discusses the function. If the indicator light keeps flashing, call for service.
Cooking results are not what you expected.	The range is level.	Level range (see Installation Instructions sheet).
	The oven was preheated before baking.	Preheat oven when called for in recipe.
	The recipe has been tested or is from a reliable source.	Use only tested recipes from a reliable source.
	The pan used is the type or size recommended in a reliable cookbook.	Refer to a reliable cookbook for recommended pan type and size.
	There is proper air circulation around the pan when baking.	Allow 1 ¹ / ₂ " to 2" (3.7-5 cm) of air space on all sides of pan.
Cooking utensil fits the surface unit being used.	Pan should be the same size or slightly larger than surface element being used.	

As ovens age, they may gradually shift in temperature. Your new oven is more exact. If, after using the oven, you are not satisfied with the temperature settings, they can be adjusted by an authorized service technician.

WARRANTY

LENGTH OF WARRANTY:	COVERED BY WARRANTY:	NOT COVERED BY WARRANTY:
ONE YEAR FULL WARRANTY FROM DATE OF PURCHASE.	Replacement parts and repair labor costs to correct defects in materials or workmanship. Service must be provided by an authorized servicing outlet.	A. Service calls to: <ol style="list-style-type: none"> 1. Correct the installation of the range. 2. Instruct you how to use the range. 3. Replace house fuses or correct house wiring.
SECOND THROUGH THIRD YEAR LIMITED WARRANTY FROM DATE OF PURCHASE.	Replacement parts for coil and oven elements to correct defects in materials or workmanship.	B. Repairs when range is used in other than normal home use. C. Damage resulting from accident, alteration, misuse, abuse, improper installation or installation not in accordance with local electrical codes.
SECOND THROUGH FIFTH YEAR LIMITED WARRANTY FROM DATE OF PURCHASE	Replacement parts for radiant elements to correct defects in materials or workmanship. Replacement glass ceramic if breakage is due to defects in materials or workmanship.	D. Any labor costs during the limited warranties. E. Replacement parts or repair labor costs for units operated outside Canada. F. Pickup and delivery. This product is designed to be repaired in the home. G. Repairs to glass ceramic cooktop if it has not been cared for as recommended in the User & Care Guide. H. Repairs to parts or systems caused by unauthorized modifications made to the appliance.

